

**Suggested Solution for 2023 HKDSE Mathematics(core) Multiple Choice Questions**

1. C

$$\frac{a+5b}{7a+2b} = \frac{1}{b+3}$$

$$(a+5b)(b+3) = 7a+2b$$

$$ab+5b^2+3a+15b = 7a+2b$$

$$5b^2+15b-2b = 7a-3a-ab$$

$$4a-ab = 5b^2+13b$$

$$a(4-b) = 5b^2+13b$$

$$a = \frac{5b^2+13b}{4-b}$$

2. C

$$\frac{2}{5-4x} - \frac{1}{5+4x}$$

$$= \frac{2(5+4x)-(5-4x)}{(5-4x)(5+4x)}$$

$$= \frac{10+8x-5+4x}{25-16x^2}$$

$$= \frac{5+12x}{25-16x^2}$$

3. A

$$4^{n+2} \cdot 3^{2n+4}$$

$$= 2^{2(n+2)} \cdot 3^{2n+4}$$

$$= 2^{2n+4} \cdot 3^{2n+4}$$

$$= (2 \cdot 3)^{2n+4}$$

$$= 6^{2n+4}$$

4. B

$$2x^2 + xy - y^2 + 4x + 4y$$

$$= (2x-y)(x+y) + 4(x+y)$$

$$= (x+y)(2x-y+4)$$

5. A

$$(x+2)(x+c) + 12 \equiv x(x+d) + 6c(x+1)$$

$$x^2 + (c+2)x + 2c + 12 \equiv x^2 + (6c+d)x + 6c$$

By comparing the coefficients,

$$6c = 2c + 12 \rightarrow c = 3$$

$$3 + 2 = 6(3) + d$$

$$d = -13$$

AlternativelySubstitute  $x = 0$  on both sides,

$$2c + 12 = 6c \rightarrow c = 3$$

Then, substitute  $x = 1^{(*)}$  on both sides,

$$(1+2)(1+3) + 12 = 1(1+d) + 6(3)(1+1)$$

$$d = -13$$

(\*) Note that any convenient number e.g.  $x = -1, -2$  or  $-3$  may also give the answer.

6. D

$$x - 3 < -5 \text{ or } \frac{6-x}{4} < 2$$

$$x > -5 + 3 \text{ or } 6 - x < 8$$

$$x > -2 \text{ or } x > -2$$

$$\therefore x \neq -2$$

7. C

The absolute error is  $\frac{0.1}{2}$  i.e. 0.05.

$$\therefore 73.8 - 0.05 \leq y < 73.8 + 0.05 \quad \text{i.e.} \quad 73.75 \leq y < 73.85$$

8. D

$$g(1 - 3a)$$

$$= 13 - 5(1 - 3a)^2$$

$$= 13 - 5(1 - 6a + 9a^2)$$

$$= 13 - 5 + 30a - 45a^2$$

$$= 8 + 30a - 45a^2$$

9. A

By Factor theorem,

$$h\left(\frac{3}{2}\right) = 0$$

$$a\left(\frac{3}{2}\right)^6 + 16\left(\frac{3}{2}\right)^3 + b = 0 \quad \text{i.e.} \quad b = -a\left(\frac{3}{2}\right)^6 - 16\left(\frac{3}{2}\right)^3 \dots(1)$$

By Factor theorem, the required remainder

$$= a\left(-\frac{3}{2}\right)^6 + 16\left(-\frac{3}{2}\right)^3 + b$$

$$= a\left(-\frac{3}{2}\right)^6 + 16\left(-\frac{3}{2}\right)^3 - a\left(\frac{3}{2}\right)^6 - 16\left(\frac{3}{2}\right)^3 \quad [\text{From(1)}]$$

$$= -108$$

10. D

$$y = 5 + (x - 3)^2$$

$$= x^2 - 6x + 14$$

Substitute  $x = 3$ ,

$$y = (3)^2 - 6(3) + 14$$

$$= 5$$

$\therefore$  The graph passes through the point (3, 5).

11. B

Let \$c\$ be the cost of the jacket.

$$(1 + 60\%)c \times (1 - 25\%) = c + 104$$

$$c = 520$$

12. D

$$\frac{\text{Area on the map}}{\text{Actual area}} = \left(\frac{1}{50000}\right)^2$$

$$\frac{\text{Area on the map}}{10} = \left(\frac{1}{50000}\right)^2$$

$$\begin{aligned} \text{Area on the map} &= 4 \times 10^{-9} \text{ km}^2 \\ &= 40 \text{ cm}^2 \end{aligned}$$

13. B

Let  $z = kx^2y^{\frac{1}{3}}$  where  $k$  is a constant.

$$\text{Then, } 36 = k(12)^2(64)^{\frac{1}{3}}$$

$$k = \frac{1}{16}$$

$$\therefore z = \frac{1}{16}x^2y^{\frac{1}{3}}$$

When  $x = 16$  and  $y = 729$ ,

$$\begin{aligned} z &= \frac{1}{16}(16)^2(729)^{\frac{1}{3}} \\ &= 144 \end{aligned}$$

Alternatively

$$36 = k(12)^2(64)^{\frac{1}{3}} \dots (1)$$

$$z = k(16)^2(729)^{\frac{1}{3}} \dots (2)$$

$$(2) \div (1),$$

$$\frac{z}{36} = \frac{k(16)^2(729)^{\frac{1}{3}}}{k(12)^2(64)^{\frac{1}{3}}}$$

$$z = 144$$

14. B

$$a_8 = a_7 + a_6$$

$$60 = a_7 + 23$$

$$a_7 = 37$$

Note that  $a_n = a_{n+2} - a_{n+1}$ 

Then,

$$a_5 = a_7 - a_6 = 37 - 23 = 14$$

$$a_4 = a_6 - a_5 = 23 - 14 = 9$$

$$a_3 = a_5 - a_4 = 14 - 9 = 5$$

15. A

Let  $r$  cm and  $h$  cm be the base radius and the height of the circular cylinder respectively.

$$\pi r^2 h = 60^3 \dots (1)$$

$$2\pi r h = 6 \times 60^2 \dots (2)$$

$$\frac{(1)}{(2)},$$

$$\frac{\pi r^2 h}{2\pi r h} = \frac{60^3}{6 \times 60^2}$$

$$r = 20$$

16. D

Note that  $G$  is the centre of the circle  $BEDF$ .

Let  $O$  be the centre of the circle  $ABCD$ .

$$\text{Note that the radius of the circle } ABCD = \frac{AC}{2} = \frac{AG+CG}{2} = \frac{30+10}{2} = 20 \text{ cm}$$

$$\text{i.e. } OA = OB = OC = OD = 20 \text{ cm}$$

Let  $r$  cm be the radius of the circle  $BEDF$ .

Note that  $DG \perp AF$ .

By Pythagoras' theorem,

$$OD^2 = DG^2 + OG^2$$

$$20^2 = r^2 + (OC - CG)^2$$

$$20^2 = r^2 + (20 - 10)^2$$

$$r = 10\sqrt{3}$$

Let  $\angle DOG = \theta$ .

$$\sin \theta = \frac{DG}{DE} = \frac{10\sqrt{3}}{20}$$

$$\theta = 60^\circ$$

By symmetry,  $\angle DOB = 2\theta = 120^\circ$

$$\text{Area of sector } OBCD = \pi(20)^2 \times \frac{120^\circ}{360^\circ} = \frac{400\pi}{3} \text{ cm}^2$$

$$\text{Area of } \triangle DOB = \frac{1}{2} \times OG \times DB = \frac{1}{2} \times 10 \times (2 \times 10\sqrt{3}) = 100\sqrt{3} \text{ cm}^2$$

$$\text{Area of segment } BCDG = \text{area of sector } OBCD - \text{area of } \triangle DOB = \left(\frac{400\pi}{3} - 100\sqrt{3}\right) \text{ cm}^2$$

Area of the shaded region = area of the circle  $ABCD$  – area of semi-circle  $DEB$  – area of segment  $BCDG$

$$= \pi(20)^2 - \frac{1}{2} \times \pi(10\sqrt{3})^2 - \left(\frac{400\pi}{3} - 100\sqrt{3}\right)$$

$$= 540 \text{ cm}^2 \text{ (correct to the nearest cm}^2\text{)}$$

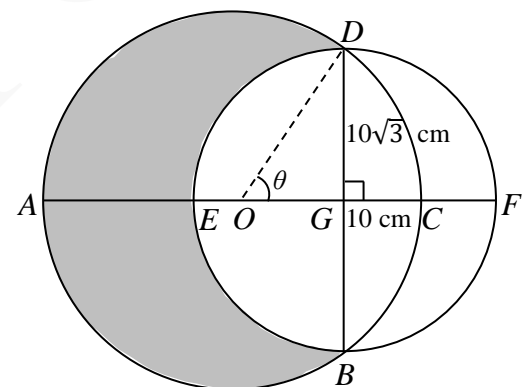

17. B

Let the area of  $\triangle RSY$  be  $x \text{ cm}^2$ .

Note that the area of  $\triangle RSP = 32 + 58 = 90 \text{ cm}^2$ .

$\therefore$  Area of  $\triangle PSY = (90 - x) \text{ cm}^2$

Note that  $\triangle RSY \sim \triangle PXY$ .

$\therefore RY : PY = SY : XY$

$\therefore \triangle PSY$  and  $\triangle RSY$  have the same height.

$\therefore$  Area of  $\triangle RSY : \text{area of } \triangle PSY = RY : PY$

$\therefore \triangle SPY$  and  $\triangle XPY$  have the same height.

$\therefore$  Area of  $\triangle SPY : \text{area of } \triangle XPY = SY : XY$

$\therefore$  Area of  $\triangle RSY : \text{area of } \triangle PSY = \text{Area of } \triangle SPY : \text{area of } \triangle XPY$  [ $\because RY : PY = SY : XY$ ]

$$x : (90 - x) = (90 - x) : 32$$

Solving,  $x = 50$  or  $162$  (rejected)

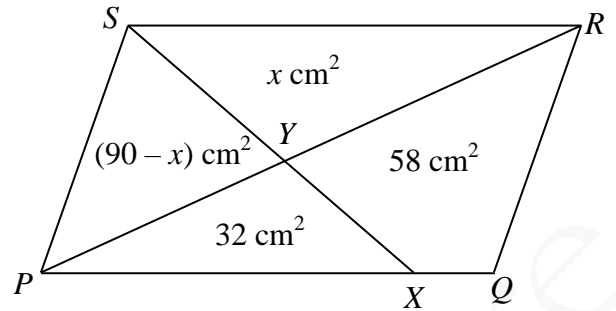

18. A

Draw a line as shown.

$\theta_1 = a$  (alt.  $\angle$ s, //lines)

$\theta_2 = b$  (alt.  $\angle$ s, //lines)

$$\theta_1 + \theta_2 = 90^\circ$$

$$\text{i.e. } a + b = 90^\circ$$

$\therefore$  I is true.

$$c + d = 180^\circ \text{ (int. } \angle\text{s, //lines)}$$

$\therefore$  II is true.

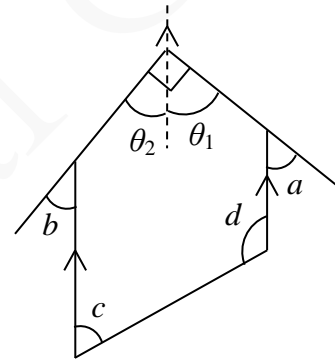

19. C

Note that  $AC \perp BD$ ,  $AE = CE$  and  $BE = DE$ . (properties of rhombus)

$$\frac{AE}{AC} = \frac{BE}{BD} = \frac{1}{2}$$

$\therefore$  II is true.

By Pythagoras' theorem,

$$AE^2 + BE^2 = AB^2 = CD^2$$

$\therefore$  III is true.

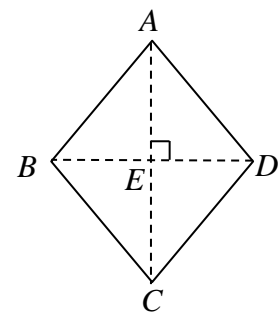

20. A

Note that  $AB = AK$ . $\therefore \angle ABK = \angle AKB$  (base  $\angle$ s, isos.  $\Delta$ ) $\angle BAD = 90^\circ$  (properties of square)

$$\begin{aligned}\angle DAG &= \frac{180^\circ \times (5-2)}{5} \quad (\angle \text{ sum of polygon}) \\ &= 108^\circ\end{aligned}$$

$$\begin{aligned}\angle KAG &= \frac{180^\circ \times (6-2)}{6} \quad (\angle \text{ sum of polygon}) \\ &= 120^\circ\end{aligned}$$

 $\angle BAK + \angle BAD + \angle DAG + \angle KAG = 360^\circ$  ( $\angle$ s at a pt.)

$$\angle BAK + 90^\circ + 108^\circ + 120^\circ = 360^\circ$$

$$\angle BAK = 42^\circ$$

 $\angle ABK + \angle AKB + \angle BAK = 180^\circ$  ( $\angle$  sum of  $\Delta$ )

$$2\angle ABK + 42^\circ = 180^\circ$$

$$\angle ABK = 69^\circ$$

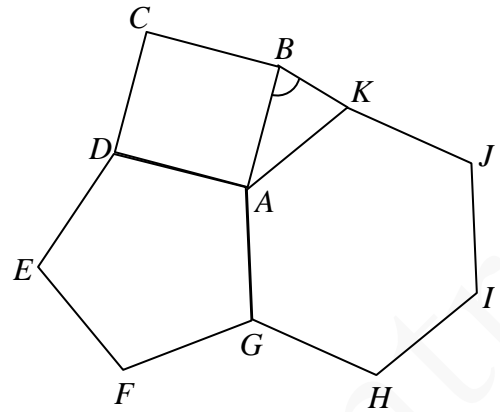

21. C

Let  $\angle SPT = \theta$ . Then,  $\angle PST = 90^\circ - \theta$ . $\angle PTQ = \theta$  (alt.  $\angle$ s,  $SP \parallel RQ$ ) $\angle UTQ + \angle PTQ + \angle PTS = 180^\circ$  (adj.  $\angle$ s on st. line)

$$\angle UTQ + \theta + 90^\circ = 180^\circ$$

$$\angle UTQ = 90^\circ - \theta$$

$$= \angle PST$$

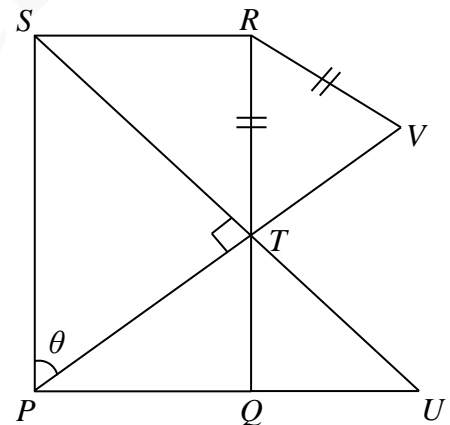
Also,  $\angle PTS = \angle UQT = 90^\circ$  $\therefore \Delta PST \sim \Delta UTQ$  (AAA)

22. B

Let  $\angle TSU = x$ . Then,  $\angle TUS = \angle TSU = x$  (base  $\angle$ s, isos.  $\Delta$ ) $\angle TRU = \angle TSU = x$  ( $\angle$ s in the same segment) $\angle TRS = \angle TUS = x$  ( $\angle$ s in the same segment)

$$\therefore \angle WRS = 2x$$

 $\angle RSU = \angle RVU + \angle TUS$  (ext.  $\angle$  of  $\Delta$ )

$$= 48^\circ + x$$

 $\angle WRS + \angle RWS + \angle RSW = 180^\circ$  ( $\angle$  sum of  $\Delta$ )

$$2x + 32^\circ + (48^\circ + x + x) = 180^\circ$$

$$\rightarrow x = 25^\circ$$

$$\begin{aligned}\therefore \angle RSU &= 48^\circ + x \\ &= 48^\circ + 25^\circ \\ &= 73^\circ\end{aligned}$$

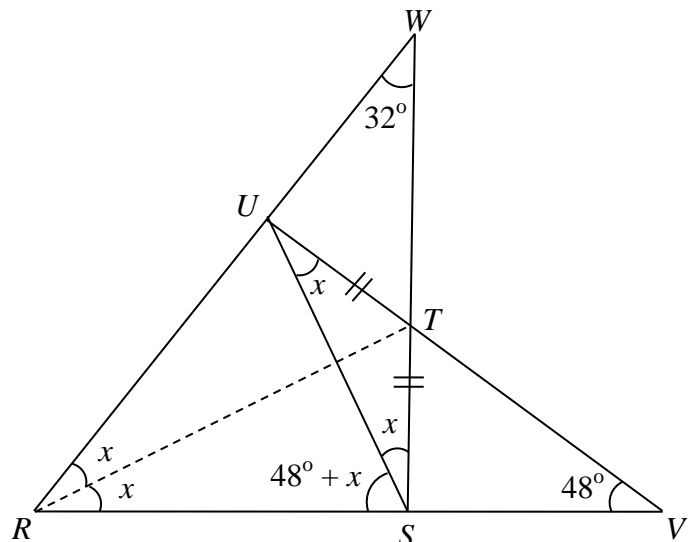

23. D

Note that  $AE = DE$  and  $\angle BEC = \alpha$ .

$$\frac{CE}{BE} = \cos \alpha \quad \text{i.e.} \quad CE = BE \cos \alpha \dots (1)$$

$$\frac{BE}{AE} = \sin \alpha$$

$$\begin{aligned} BE &= AE \sin \alpha \\ &= DE \sin \alpha \dots (2) \end{aligned}$$

Combining (1) and (2),

$$CE = DE \sin \alpha \cos \alpha$$

$$\text{i.e.} \quad \frac{CE}{DE} = \sin \alpha \cos \alpha$$

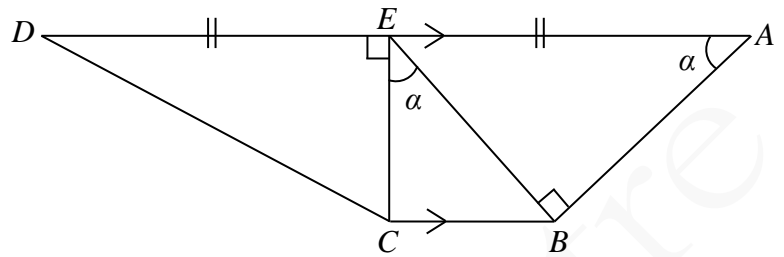

24. C

After anticlockwise rotation, the coordinates of the image of  $P(P')$  are  $(\sqrt{2}, \sqrt{2})$ .

Refer to the figure on the right.

$$\tan \theta = \frac{\sqrt{2}}{\sqrt{2}} = 1$$

$$\rightarrow \theta = 45^\circ$$

$$\begin{aligned} r &= \sqrt{(\sqrt{2})^2 + (\sqrt{2})^2} \\ &= 2 \end{aligned}$$

$\therefore$  The required polar coordinates are  $(2, 45^\circ)$ .

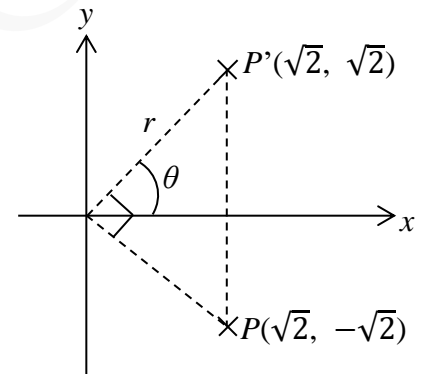

25. A

Rewrite the equations of the two straight lines in slope-intercept form.

$$y = -\frac{2}{a+3}x + \frac{5}{a+3}$$

$$y = \frac{a}{4}x + \frac{1}{4}$$

$\therefore$  They are perpendicular to each other

$$\therefore -\frac{2}{a+3} \times \frac{a}{4} = -1$$

$$a = -6$$

26. B

Rewrite the equations of  $\ell$  and  $L$  in slope-intercept form.

$$\ell: y = -\frac{3}{4}x + \frac{37}{12}$$

$$L: y = -\frac{3}{4}x - \frac{85}{16}$$

$\therefore \ell \parallel L$  and the  $y$ -intercepts of  $\ell$  and  $L$  are  $\frac{37}{12}$  and  $-\frac{85}{16}$  respectively.

The locus of  $\Gamma$  must be a straight line running between  $\ell$  and  $L$  and parallel to both of them.

$\therefore$  I is true.

$$\text{The } y\text{-intercept of } \Gamma = \frac{\frac{37}{12} + (-\frac{85}{16})}{2} = -\frac{107}{96}$$

$\therefore$  The equation of  $\Gamma$  is  $y = -\frac{3}{4}x - \frac{107}{96}$ .

For  $\ell$ , put  $y = 0$ ,

$$9x + 12(0) - 37 = 0$$

$$x = \frac{37}{9} \text{ i.e. The } x\text{-intercept of } \ell \text{ is } \frac{37}{9}.$$

$\therefore A = (\frac{37}{9}, 0)$  and  $B = (0, -\frac{85}{16})$ .

$$m_{AB} = \frac{-\frac{85}{16} - 0}{0 - \frac{37}{9}} = \frac{765}{592}$$

$$m_{AB} \times m_{\Gamma}$$

$$= \frac{765}{592} \times -\frac{3}{4}$$

$$= -\frac{2295}{2368}$$

$\neq 1$

$\therefore$  II is NOT true.

The mid-pt. of  $AB = \left(\frac{\frac{37}{9} + 0}{2}, \frac{0 + (-\frac{85}{16})}{2}\right)$  i.e.  $(\frac{37}{18}, -\frac{85}{32})$

Substitute  $x = \frac{37}{18}$  into the R.H.S. of the equation of  $\Gamma$ ,

$$-\frac{3}{4}\left(\frac{37}{18}\right) - \frac{107}{96} = -\frac{85}{32}$$

$\therefore \Gamma$  passes through the mid-pt. of  $AB$ .

$\therefore$  III is true.

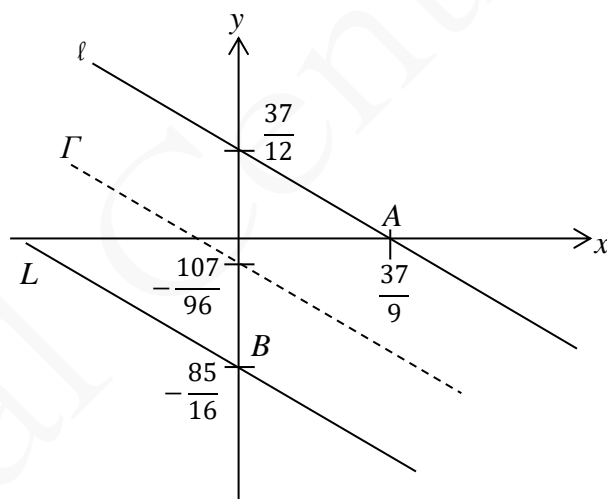



27. C

$$\text{Note that } C_2 : x^2 + y^2 - x - 8y - \frac{17}{2} = 0$$

$$G_1 = \left( \frac{-7}{2}, \frac{-(-4)}{2} \right) = \left( \frac{-7}{2}, 2 \right)$$

$$G_2 = \left( \frac{-(-1)}{2}, \frac{-(-8)}{2} \right) = \left( \frac{1}{2}, 4 \right)$$

$$OG_1 = \sqrt{\left( -\frac{7}{2} - 0 \right)^2 + (2 - 0)^2} = \frac{\sqrt{65}}{2}$$

$$OG_2 = \sqrt{\left( \frac{1}{2} - 0 \right)^2 + (4 - 0)^2} = \frac{\sqrt{65}}{2}$$

$$G_1G_2 = \sqrt{\left( -\frac{7}{2} - \frac{1}{2} \right)^2 + (2 - 4)^2} = 2\sqrt{5}$$

∴ I is NOT true.

$$\text{Radius of } C_2, r_2 = \sqrt{\left( \frac{1}{2} \right)^2 + 4^2 - \left( -\frac{17}{2} \right)} = \frac{\sqrt{99}}{2} / \frac{3\sqrt{11}}{2} > 2\sqrt{5}$$

i.e.  $G_1$  lies inside  $C_2$ .

$$\text{Also, } \frac{\sqrt{99}}{2} > \frac{\sqrt{65}}{2}$$

∴  $O$  lies inside  $C_2$ .

∴  $OG_1$  must lie inside  $C_2$ .

∴ II is true.

$$\text{Radius of } C_1, r_1 = \sqrt{\left( -\frac{7}{2} \right)^2 + 2^2 - 15} = \frac{\sqrt{5}}{2}$$

$$r_1 + r_2$$

$$= \frac{\sqrt{5}}{2} + \frac{\sqrt{99}}{2}$$

$$> 2\sqrt{5} = G_1G_2$$

∴  $C_1$  and  $C_2$  intersects at two distinct points.

∴ III is true.

28. D

Refer to the table on the right. The numbers circled are divisible by 4.

The required probability

$$= \frac{9}{20}$$

1<sup>st</sup> box2<sup>nd</sup> box

	1	2	3	4	5
6	6	12	18	24	30
7	7	14	21	28	35
8	8	16	24	32	40
9	9	18	27	36	45

29. C

From the box-and-whisker diagram, the upper quartile of the distribution is 60.

30. A

The mean salary

$$= \$ \frac{31530 \times 14 + 21525 \times 56}{214 + 56}$$

$$= \$23\,526$$

31. B

$$1011001011001011_2$$

$$= 1 \times 2^{15} + 1 \times 2^{13} + 1 \times 2^{12} + 1 \times 2^9 + 1 \times 2^7 + 1 \times 2^6 + 1 \times 2^3 + 1 \times 2^1 + 1 \times 2^0$$

$$= (2^3 + 2^1 + 1) \times 2^{12} + (2^3 + 2^1 + 1) \times 2^6 + (8 + 2 + 1)$$

$$= 11 \times 2^{12} + 11 \times 2^6 + 11$$

32. D

Taking the largest degree from  $a$ ,  $b$  and  $c$ , the L.C.M. is  $a^4b^5c^2$ .

33. A

Slope of the graph of the linear function =  $\frac{5-0}{0-3} = -\frac{5}{3}$ . Then, the equation of the linear function is

$$\log_8 y = -\frac{5}{3} \log_4 x + 5$$

$$= \log_4 x^{-\frac{5}{3}} + \log_4 4^5$$

$$= \log_4 (4^5 x^{-\frac{5}{3}})$$

$$\frac{\log y}{\log 8} = \frac{\log(4^5 x^{-\frac{5}{3}})}{\log 4} \quad [\text{using change of base formula}]$$

$$\frac{\log y}{3 \log 2} = \frac{\log(4^5 x^{-\frac{5}{3}})}{2 \log 2}$$

$$\log y = \log \left( 4^5 x^{-\frac{5}{3}} \right)^{\frac{3}{2}}$$

$$= \log \left( 4^{\frac{3}{2} \times 5} x^{-\frac{5}{2}} \right)$$

$$= \log \left( 8^5 x^{-\frac{5}{2}} \right)$$

$$\therefore y = 8^5 x^{-\frac{5}{2}} \quad \rightarrow \quad x^5 y^2 = 8^{10}$$

34. B

$$\begin{aligned} & \frac{i}{k-i} + \frac{2}{k+i} \\ &= \frac{i(k+i)+2(k-i)}{(k-i)(k+i)} \\ &= \frac{ki+i^2+2k-2i}{k^2-i^2} \\ &= \frac{ki-1+2k-2i}{k^2+1} \\ &= \frac{2k-1}{k^2+1} + \frac{k-2}{k^2+1}i \\ \therefore \text{ The real part} &= \frac{2k-1}{k^2+1} \end{aligned}$$

35. D

$$\begin{aligned} y &= -f(3x) \\ &= -[3(3x)^2 + 18m(3x) + 22m^2] \\ &= -(27x^2 + 54mx + 22m^2) \\ &= -27(x^2 + 2mx + m^2) + 5m^2 \\ &= -27(x+m)^2 + 5m^2 \\ \therefore \text{ The vertex of the graph} &= (-m, 5m^2) \\ \therefore \text{ I is NOT true and II is true.} \\ \text{The equation of the axis of symmetry of the graph is } x+m &= 0. \\ \therefore \text{ III is true.} \end{aligned}$$

36. B

$$\begin{aligned} \text{Let } T(1) &= a \text{ and the common difference} = d. \text{ Then,} \\ a + 10d &= 83 \dots (1) \\ (a + 24d) + (a + 29d) &= 463 \quad \text{i.e. } 2a + 53d = 463 \dots (2) \\ \text{Solving (1) and (2),} \\ a &= -7 \text{ and } d = 9 \\ \therefore T(1) + T(2) + T(3) + \dots + T(k) &> 4 \times 10^5 \\ \therefore \frac{k}{2}[2(-7) + (k-1)(9)] &> 4 \times 10^5 \\ 9k^2 - 23k - 8 \times 10^5 &> 0 \\ k &< -296.8673574 \text{ (rejected) or } k > 299.4229129 \\ \therefore \text{ The least value of } k &\text{ is 300.} \end{aligned}$$

37. D

$$\begin{cases} x + 3 = 0 \dots (1) \\ 2x + 3y - 12 = 0 \dots (2) \\ 5x - 3y + 12 = 0 \dots (3) \end{cases}$$

Solving (1) and (2), the intersection of (1) and (2) is  $(-3, 6)$ .

Similarly, the intersection of (1) and (3) is  $(-3, -1)$

while that of (2) and (3) is  $(0, 4)$ .

Let  $P(x, y) = \beta x + 6y$

$$P(-3, 6) = \beta(-3) + 6(6) \leq 24 \rightarrow \beta \geq 4$$

$$P(-3, -1) = \beta(-3) + 6(-1) \leq 24 \rightarrow \beta \geq -10$$

$$P(0, 4) = \beta(0) + 6(4) = 24$$

$\therefore$  Combining the results,  $\beta \geq 4$ .

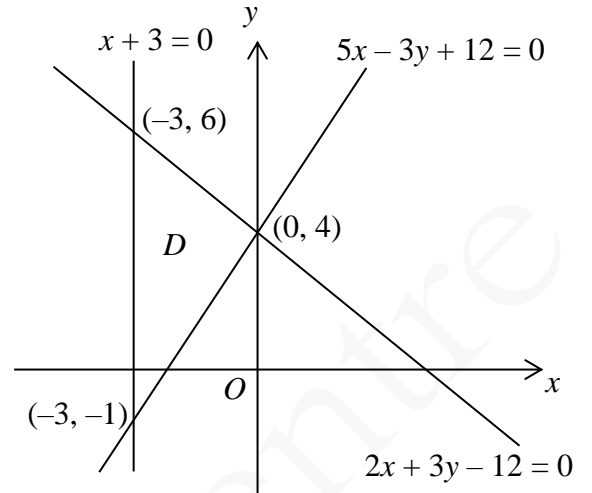

38. C

Join  $PR$ .

$\therefore SP = SR$  (tangent properties)

$\therefore \angle SPR = \angle SRP$  (base s, isos.  $\Delta$ )

$\angle SPR + \angle SRP + \angle PSR = 180^\circ$  ( $\angle$  sum of  $\Delta$ )

$$2\angle SPR + 34^\circ = 180^\circ$$

$$\angle SPR = 73^\circ$$

$\angle PQR = \angle SPR = 73^\circ$  ( $\angle$  in alt. segment)

$\angle PVQ + \angle QPT = \angle PQR$  (ext.  $\angle$  of  $\Delta$ )

$$\angle PVQ + 46^\circ = 73^\circ$$

$$\angle PVQ = 27^\circ$$

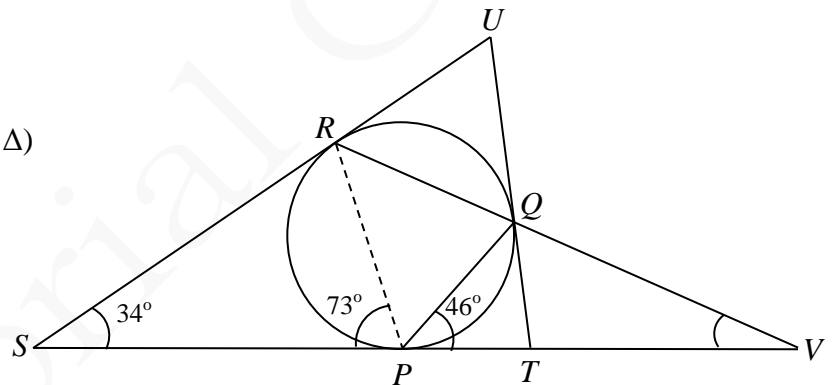

Alternatively

Let  $O$  be the centre of the circle.

Then,  $\angle ORS = \angle OPS = 90^\circ$  (tangent  $\perp$  radius)

$\angle POR + \angle PSR + \angle ORS + \angle OPS = 360^\circ$  ( $\angle$  sum of polygon)

$$\angle POR + 34^\circ + 90^\circ + 90^\circ = 360^\circ$$

$$\angle POR = 146^\circ$$

$2\angle PQR = \angle POR$  ( $\angle$  at centre twice  $\angle$  at  $\odot^{ce}$ )

$$\angle PQR = 73^\circ$$

$\angle PVQ + \angle QPT = \angle PQR$  (ext.  $\angle$  of  $\Delta$ )

$$\angle PVQ + 46^\circ = 73^\circ$$

$$\angle PVQ = 27^\circ$$

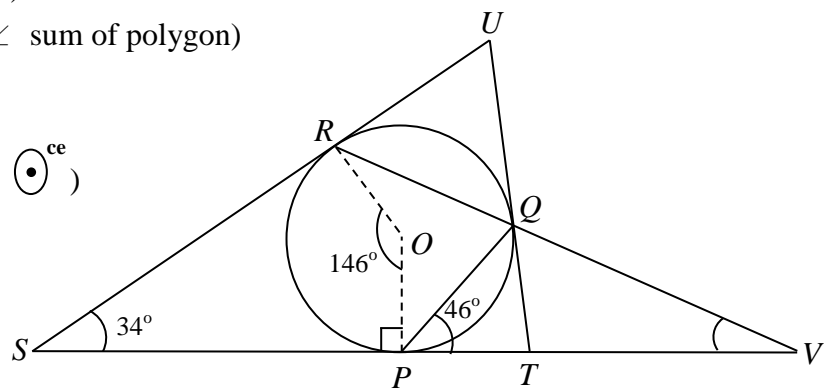

39. A

Let  $O$  be the centre of the circle. Then, the coordinates of  $O$  are  $(-\frac{-8}{2}, -\frac{-4}{2})$ . i.e.  $(4, 2)$

Let  $P = (1, 0)$ .  $P$  is a point on the straight line  $hx + ky = 6$ .

Then,  $h(1) + k(0) = 6$  i.e.  $h = 6$

$$\text{Slope of } MN = -\frac{h}{k} = -\frac{6}{k}$$

$\therefore OP \perp MN$  (line from centre to mid-pt. of chord  $\perp$  chord)

$$\therefore m_{OP} \times m_{MN} = -1$$

$$\text{i.e. } \frac{2-0}{4-1} \times \left(-\frac{6}{k}\right) = -1$$

$$\therefore k = 4$$

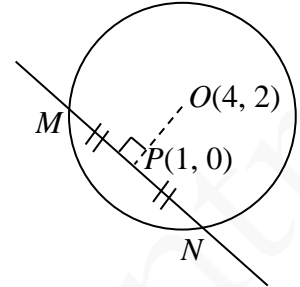

40. A

Let  $T$  be the foot of perpendicular from  $A$  to  $BV$ . By symmetry,  $T$  is also the foot of perpendicular from  $C$  to  $BV$ . Then,  $AT = CT$  and  $\angle ATC = \theta$ .

Let  $\angle ABT = \angle CBT = \alpha$ . Let  $AB = 5k$  and  $AV = BV = CV = DV = 4k$  where  $k$  is a constant.

By cosine formula,

$$AV^2 = AB^2 + BV^2 - 2(AB)(BV)\cos \alpha.$$

$$(4k)^2 = (5k)^2 + (4k)^2 - 2(5k)(4k)\cos \alpha$$

$$\rightarrow \cos \alpha = \frac{5}{8}$$

$$\sin^2 \alpha + \cos^2 \alpha = 1$$

$$\sin \alpha = \frac{\sqrt{39}}{8}$$

$$\frac{AT}{AB} = \sin \alpha = \frac{\sqrt{39}}{8}$$

$$AT = (5k)\left(\frac{\sqrt{39}}{8}\right) = \frac{5\sqrt{39}k}{8}$$

By Pythagoras's Theorem,

$$\begin{aligned} AC^2 &= AB^2 + BC^2 \\ &= (5k)^2 + (5k)^2 \\ &= 50k^2 \end{aligned}$$

By cosine formula,

$$AC^2 = AT^2 + CT^2 - 2(AT)(CT)\cos \theta$$

$$50k^2 = \left(\frac{5\sqrt{39}k}{8}\right)^2 + \left(\frac{5\sqrt{39}k}{8}\right)^2 - 2\left(\frac{5\sqrt{39}k}{8}\right)\left(\frac{5\sqrt{39}k}{8}\right)\cos \theta$$

$$\cos \theta = -\frac{25}{39}$$

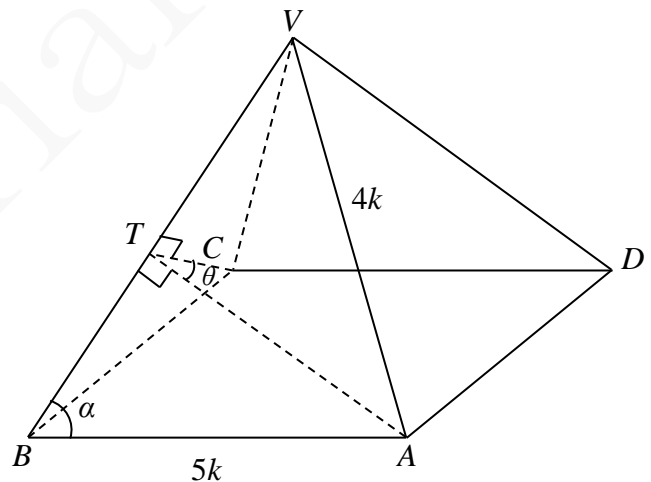

41. C

Let  $R = (a, b)$ . Let  $G$  be the in-centre of  $\triangle PQR$ .

Then,  $\angle QPG = \angle RPG = \theta$ .

Substitute  $y = 0$  into  $L_1$ ,

$$3x - 4(0) + k = 0$$

$$\rightarrow x = -\frac{k}{3} \text{ i.e. The } x\text{-intercept of } L_1 \text{ is } -\frac{k}{3}.$$

$\therefore R$  is a point lying on  $L_2$

$$\therefore 4(a) + 3(b) - k = 0$$

$$b = -\frac{4a}{3} + \frac{k}{3}$$

$$\text{Rewrite } L_1 \text{ as } y = \frac{3}{4}x + \frac{k}{4} \text{ i.e. } m_1 = \frac{3}{4}$$

$$\therefore \tan \theta = \frac{3}{4}$$

$$\text{i.e. } \frac{-b}{a - \left(-\frac{k}{3}\right)} = \frac{3}{4}$$

$$\frac{-\left(-\frac{4a}{3} + \frac{k}{3}\right)}{a - \left(-\frac{k}{3}\right)} = \frac{3}{4}$$

$$\rightarrow a = k$$

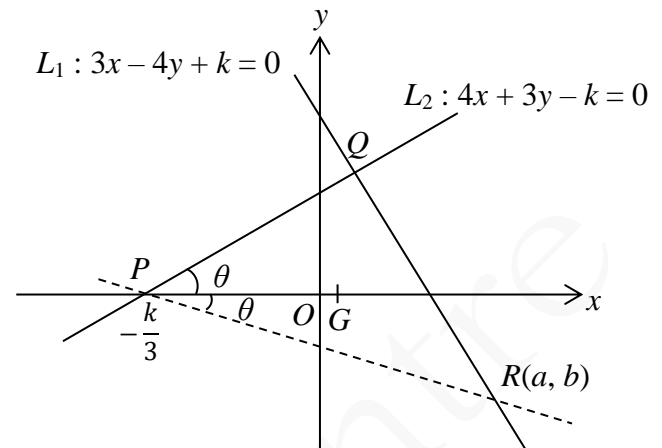

42. B

Number of committees

= Number of ways of selecting 5 teachers from the group  $\times$  number of ways selecting the chairperson

$$= C_5^{15} \times C_1^5$$

$$= 15\ 015$$

43. C

The required probability

$$= 1 - P(\text{"hit no time"}) - P(\text{"hit 1 time"})$$

$$= 1 - (1 - 0.6)^4 - C_1^4(0.6)(1 - 0.6)^3$$

$$= 0.8208$$

44. D

Let  $\mu$  and  $\sigma$  be the mean and standard deviation of the scores in the examination. Then,

$$\frac{46 - \mu}{\sigma} = -3 \dots (1)$$

$$\frac{86 - \mu}{\sigma} = 2 \dots (2)$$

Solving (1) and (2),  $\mu = 70$  and  $\sigma = 8$ .

$$\therefore \frac{x - 70}{8} = 1$$

$$\rightarrow x = 78$$

45. A

The mean of the group of numbers,  $\bar{x} = \frac{1-9n+3-9n+4-9n+5-9n+7-9n}{5} = 4 - 9n$

$$u = \sqrt{\frac{[(1-9n)-(4-9n)]^2 + [(3-9n)-(4-9n)]^2 + [(4-9n)-(4-9n)]^2 + [(5-9n)-(4-9n)]^2 + [(7-9n)-(4-9n)]^2}{5}}$$

$$= 2$$

$\therefore$  I is true.

$$v = 4 - 9n > 4 \text{ for } n < 0$$

$\therefore$  II may not be true.

$$w = (7 - 9n) - (1 - 9n) = 6$$

$\therefore$  III is not true.